

MULTIPLE MEMBER ENGINEERED WOOD BEAMS

CONNECTION DETAILS

The TrussLok Engineered Wood Fastener has been designed specifically for use in joining multiple-ply engineered wood beams (LVL, LSL & PSL). Using a standard corded or cordless 1/2" low speed/high torque drill, install screws into the side of the outermost ply. As the thread fully engages the final ply, allow the underside of the washer head to pull the plies firmly together. Do not attempt to countersink the fasteners as this may damage the beam. Refer to the information in this bulletin for proper fastener size selection and fastening pattern.



FASTENER SIZE SELECTION

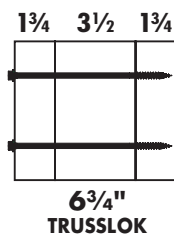
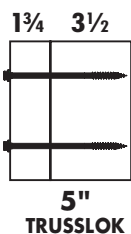
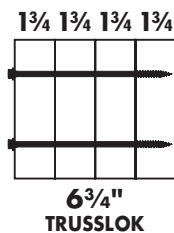
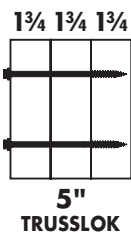
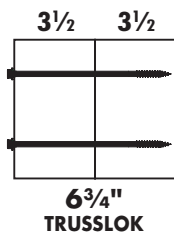
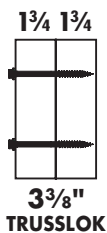

FASTENER IDENTIFICATION

For easier selection and post-installation inspection, all TrussLok fasteners carry an identifying head marking.

TrussLok 3 3/8" F3.3
 TrussLok 5" F5.0
 TrussLok 6 3/4" F6.7

MINIMUM SPACING REQUIREMENTS

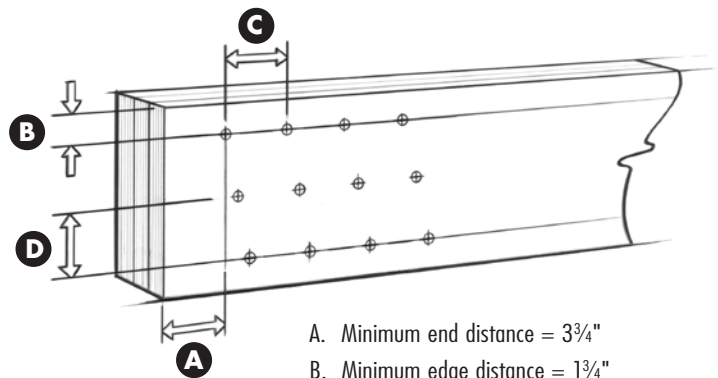

- A. Minimum end distance = 3 3/4"
- B. Minimum edge distance = 1 3/4"
- C. Minimum spacing between fasteners in a row = 3 1/2"
- D. Minimum spacing between rows of fasteners = 5/8"

GENERAL GUIDELINES

- Beams wider than 7" require special consideration by the design professional. The values on the next page do not apply.
- Excessively warped or curved LVL should never be forced into alignment by use of clamps, screws or bolts as splitting may occur, potentially decreasing the carrying capacity of the beam.
- To avoid damaging the beam, fastener heads must not be countersunk. However, if the TrussLok head needs to be brought flush, prepare the outermost ply with a countersink before installing. Using a 1/2" spade bit, drill a 1/4" deep well into the LVL in the desired fastening pattern, then install the TrussLok flush.
- Not designed for use with dimensional lumber. Use FastenMaster's TrussLok-Z fastener for multiple member dimensional wood beams.
- A qualified designer or engineer should always be consulted for critical assemblies and fastening requirements.



Effective until December 31, 2010. Updated information must be obtained after this date.

153 BOWLES ROAD, AGAWAM, MA 01001

413-789-0252

800-518-3569

WWW.FASTENMASTER.COM

FASTENING PATTERN

Top Loaded Beams

Where all floor joists sit on the beam, fasteners should be spaced two every 24" on center in a staggered pattern as shown.

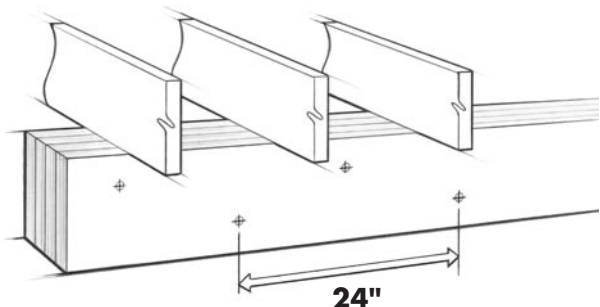

For beam depths of 18" or more, this pattern should be increased to three fasteners every 24" on center.

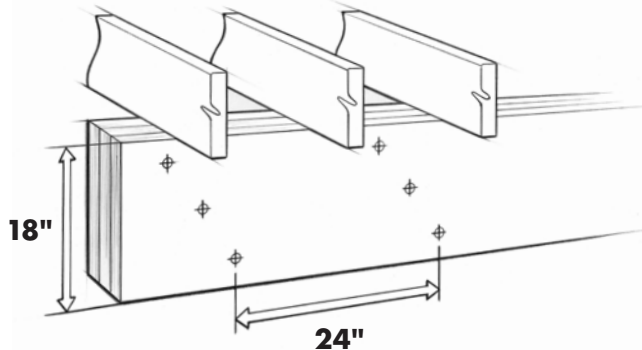

Side Loaded Beams

Where floor joists are joined to the side of the beam (typically using a joist hanger), this load chart must be used to establish the proper pattern based on the design load as determined by the engineer and noted on the plans.

- Allowable loads are derived from tested fastener values as reported in ESR #1078 (see www.icc-es.org).
- A specific gravity of 0.5 was used for all engineered wood (EW) calculations.
- The uniform loads in this table relate only to the capacity of the fastener to transfer shear loads between plies. The capacity of the EW beam may be less and should be checked against the manufacturer's literature.
- Values listed reflect 100% stress level ($C_p=1.0$). The designer may apply adjustment factors to increase or decrease these loads per 2005 NDS based on conditions for each assembly.
- To minimize rotation, 7" wide beams shall be side loaded only when loads are applied to both sides of the beam with the lesser loaded side bearing at least 25% of the overall design load.

Assembly Type

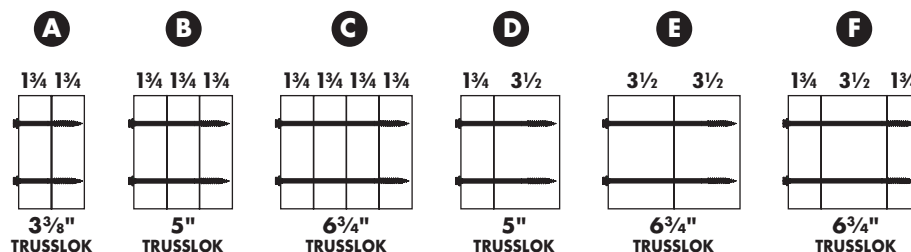

TRUSSLOK	SCREWS	SPACING	ALLOWABLE SIDE LOADS BY ASSEMBLY TYPE					
			A	B	C	D	E	F
3 3/8"	2	24"	534					
	2	16	801					
	2	12	1068					
	3	24	801					
	3	16	1202					
	3	12	1602					
5"	2	24"		433		433		
	2	16		649		649		
	2	12		866		866		
	3	24		649		649		
	3	16		974		974		
	3	12		1299		1299		
6 3/4"	2	24"			387		580	387
	2	16			580		870	580
	2	12			773		1160	773
	3	24			580		870	580
	3	16			870		1305	870
	3	12			1160		1740	1160