



CERTIFICATION



Approved. Sealed. Code Compliant.

Technical Evaluation Report

TER 1608-02

Use of FastenMaster® FrameFAST™
Structural Wood Screw Fasteners to
Provide Uplift & Lateral Resistance to
Wood Trusses & Rafters Attached to the
Tops of Walls – Limit States Design

**OMG, Inc.
DBA FastenMaster®**

Product:

**FastenMaster® FrameFAST™
Structural Wood Screw
(FrameFAST™ Fasteners)**

Issue Date:

October 18, 2016

Revision Date:

June 21, 2021

Subject to Renewal:

July 1, 2022

For the most recent version or a sealed copy of this Technical Evaluation Report (TER), visit drjcertification.org.



COMPANY
INFORMATION:

OMG, Inc.
DBA FastenMaster®

153 Bowles Rd
Agawam, MA 01001-2908

800-518-3569

mguthrie@omginc.com

fastenmaster.com

DIVISION: 06 00 00 - WOOD, PLASTICS AND COMPOSITES

SECTION: 06 00 90 - Wood and Plastic Fastenings

1 PRODUCT EVALUATED¹

- 1.1 FastenMaster® FrameFAST™ Structural Wood Screw
(FrameFAST™ Fasteners)

2 APPLICABLE CODES AND STANDARDS^{2,3}

2.1 Codes

- 2.1.1 *NBC—10, 15: National Building Code of Canada*
- 2.1.2 *NECB—17: National Energy Code of Canada for Buildings*

2.2 Standards and Referenced Documents

- 2.2.1 *ASTM A153: Standard Specification for Zinc Coating (Hot-Dip) on Iron and Steel Hardware*
- 2.2.2 *ASTM D1761: Standard Test Methods for Mechanical Fasteners in Wood*
- 2.2.3 *ASTM F1575: Standard Test Method for Determining Bending Yield Moment of Nails*
- 2.2.4 *ASTM F606: Standard Test Method for Determining Properties of Fasteners*
- 2.2.5 *CSA O86: Engineering Design in Wood*

¹ For more information, visit drjcertification.org or call us at 608-310-6748.

² Unless otherwise noted, all references in this TER are from the 2015 version of the *NBC*. This *alternative solution* is also approved for use with the 2010 *NBC* and the standards referenced therein.

³ All terms defined in the applicable building codes are italicized.

3 PERFORMANCE EVALUATION

- 3.1 FrameFAST™ fasteners were evaluated, using assembly tests to derive factored design values, as an alternative means of attaching metal-plate-connected wood trusses and rafters to the tops of walls for the purpose of providing uplift and lateral-load resistance. The following conditions were evaluated:
 - 3.1.1 Withdrawal strength of FrameFAST™ fasteners for use as an alternative to toe-nail connections, metal hurricane and seismic clips/straps, or nails in tension (uplift) loaded applications.
 - 3.1.2 Shear strength of FrameFAST™ fasteners for use as an alternative to toe-nail connections, hurricane and seismic clips/straps, or nails in shear (lateral) loaded applications either parallel or perpendicular to wood grain.
 - 3.1.3 Head-pull-through strength of FrameFAST™ fasteners for use as an alternative to toe-nail connections, hurricane and seismic clips/straps or nails in tension (uplift) loaded applications.
- 3.2 Connections other than those addressed in Section 3 are outside the scope of this TER.
- 3.3 Any code compliance issues not specifically addressed in this section are outside the scope of this TER.
- 3.4 Any engineering evaluation conducted for this TER was performed on the dates provided in this TER and within DrJ’s professional scope of work.
- 3.5 Douglas Consultants Inc. has collaborated with DrJ through the review of this technical evaluation.

4 PRODUCT DESCRIPTION AND MATERIALS

- 4.1 The product evaluated in this TER is shown in Figure 1.

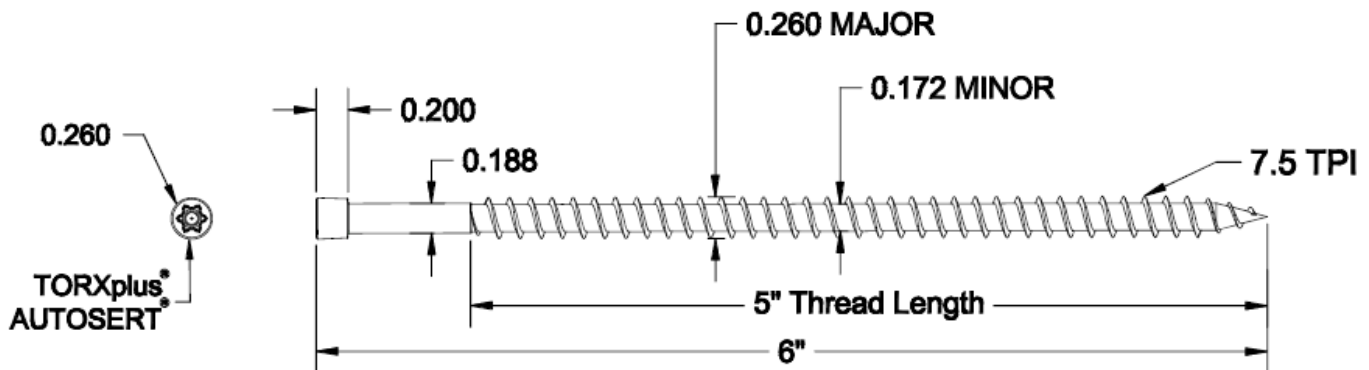

FIGURE 1. FASTENER DESIGNATION FOR THE EVALUATED FRAMEFAST™ FASTENERS

- 4.2 FrameFAST™ fasteners are manufactured with modified 10B21 carbon steel wire conforming to the manufacturer’s specifications and are coated with a proprietary finish.
- 4.3 FrameFAST™ fasteners are manufactured using a standard cold-formed process followed by a heat-treating process.
- 4.4 Fasteners are approved for use in fire-retardant-treated lumber, provided the conditions set forth by the fire-retardant-treated lumber manufacturer are met, including appropriate strength reductions.
- 4.5 FrameFAST™ fasteners are approved for use in interior and exterior conditions and in pressure-treated wood.
- 4.6 In-plant quality-control procedures, under which the FrameFAST™ fasteners are manufactured, are audited through an inspection process performed by an approved agency.

4.7 The FrameFAST™ fasteners evaluated in this TER are designated as shown in Table 1.

TABLE 1. FASTENER SPECIFICATIONS

Fastener	Fastener Designation	Fastener Length ¹ (mm)	Thread Length ¹ (mm)	Head Diameter (mm)	Head Height (mm)	Shank Diameter (mm)	Minor Thread (Root) Diameter (mm)	Major Thread Diameter (mm)	Minimum Yield ² , f_y (MPa)
FrameFAST™	FMFF006	152	127	6.6	5.1	4.8	4.4	6.6	1150

SI: 25.4 mm = 1", 1 MPa = 145 psi,

1. Fastener length is measured from the underside of the head to the tip. Thread length includes tapered tip (Figure 1).
2. Yield strength value determined at minor (root) diameter.

5 APPLICATIONS

5.1 FrameFAST™ fasteners are used to attach minimum 38-mm-wide wood trusses and sawn lumber rafters to wood walls that meet the requirements of *NBC* Section 9.23 for wood structural framing members. The fasteners provide resistance to uplift or lateral loads applied parallel and/or perpendicular to the wall or to the structural framing member.

- 5.1.1 Walls shall consist of a single or double top plate designed in accordance with *NBC* Subsection 9.23.11.
- 5.1.2 See Table 2 for the design procedure and the FrameFAST™ fasteners' allowable design values.
- 5.1.3 See Section 6 for installation requirements.

5.2 FrameFAST™ fasteners are used in buildings requiring wind and seismic analysis in accordance with *NBC* Subsection 4.1.7 and 4.1.8.

5.3 Where the application exceeds the limitations set forth herein, design shall be permitted in accordance with accepted engineering procedures, experience, and technical judgment.

5.4 Design Concepts and Resistances

- 5.4.1 The uplift and lateral resistance [parallel (F1) and perpendicular (F2)] to the plane of the wall or structural member, Figure 2, are provided in Table 2 for FrameFAST™ fasteners. Resistances are applicable to fasteners installed in accordance with the procedures described in Section 6. Resistances are applicable to both single- and double-top-plate applications as shown in Figure 3 and Figure 4.

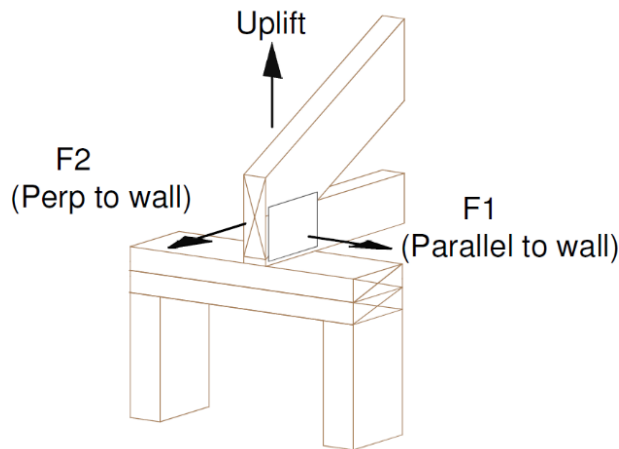

FIGURE 2. UPLIFT & LATERAL LOAD ORIENTATIONS

TABLE 2. SPECIFIED UPLIFT & LATERAL RESISTANCE OF FRAMEFAST™ FASTENERS FOR SELECTED WOOD RELATIVE DENSITIES

Fastener Designation	Penetration into Truss/Rafter/Wood Structural Support ¹ (mm)	Visually Graded Lumber (Relative Density) ^{2,3}	Specified Uplift ^{4,5,6} (kN)	Specified Lateral Resistance ^{5,6} (kN)	
				F1 Parallel to Wall	F2 Perpendicular to Wall
FMFF006	63	Southern Pine (0.55)	3.7	2.0	3.5
		Douglas Fir-Larch (0.50)	3.5	2.2	3.2
		Spruce-Pine-Fir/Hem-Fir (0.42)	3.2	2.4	2.9

SI: 25.4 mm = 1", 1 kN = 224.8 lbf

- Wood truss and rafter members shall be a minimum of 38 mm (1.5") thickness. Design of truss and rafter members shall be by others.
- Equivalent relative density of structural composite lumber (SCL) shall be equal to or greater than the relative densities provided in this table. Refer to product information from SCL manufacturer.
- For applications involving members with different relative densities, use a resistance corresponding to the lowest relative density. Install screws so that the threaded part is half in the top plates, half in the truss members.
- Use reduction factor of 0.80 when connecting each ply of multi-ply trusses to the top plate.
- Specified loads shall be multiplied by the appropriate factors per Clause 12 of CSA O86.
- An increase of 1.15 for short-term load duration may be applied where appropriate. See Table 5.3.2.2 of CSA O86.

5.4.2 Where it is anticipated that loads will be applied to a single fastener simultaneously in more than one direction, additional evaluation is required to account for the combined effect of these loads using the provisions of CSA O86.

5.4.2.1 Consult a professional engineer, as needed, for complex design conditions.

6 INSTALLATION

6.1 Installation shall comply with the manufacturer's installation instructions and this TER. In the event of a conflict between the manufacturer's installation instructions and this TER, the more restrictive shall govern.

6.2 Installation Procedure

6.2.1 Select a FrameFAST™ fastener with a length sufficient to fully embed 63 mm (2.5") of the fastener length into the truss or rafter, while conserving at least 60 mm (2.4") of thread in the top plates and stud. See Figure 3 and Figure 4 for guidance.

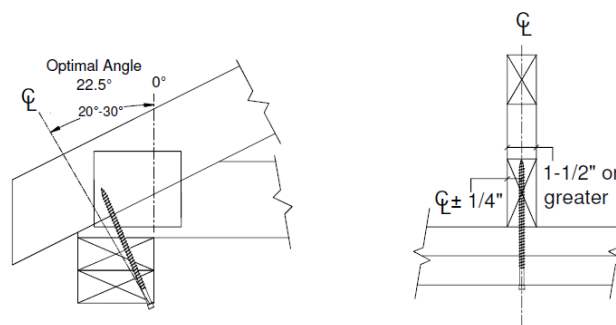

FIGURE 3. INSTALLATION OF FRAMEFAST™ FASTENERS ON WOOD TRUSS OR RAFTER TO DOUBLE TOP PLATE

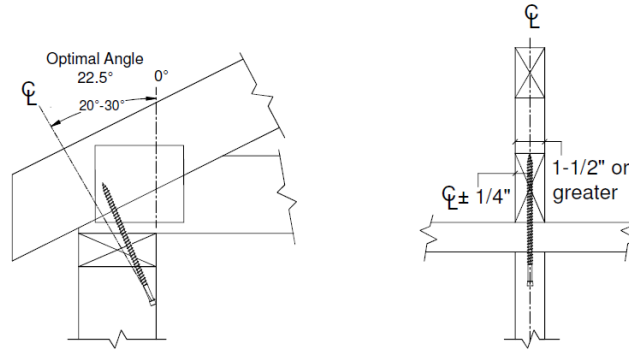

FIGURE 4. INSTALLATION OF FRAMEFAST™ FASTENERS ON WOOD TRUSS OR RAFTER TO SINGLE TOP PLATE

- 6.2.2 Install one (1) FrameFAST™ fastener upward through the wall top plates or wood structural framing member at the bottom corner of the top plates and into the center of the wood truss or rafter. The fastener should be installed at a 20°-30° angle and should penetrate the wood truss or rafter within 6 mm of the centerline (Figure 3 and Figure 4).
 - 6.2.2.1 If the wood truss or rafter is located directly over a top plate splice, offset the fastener 6 mm to one side of the splice and insert the fastener upward through the wall top plates or wood structural framing member at the bottom corner of the top plates and into the center of the truss or rafter. The fastener should be installed at a 20°-30° angle.
- 6.2.3 Use a low-RPM high-torque 1/2" drill to drive the fastener head flush with the surface of the wall framing or wood structural framing member.

7 SUBSTANTIATING DATA

- 7.1 Testing has been performed under the supervision of a professional engineer and/or under the requirements of ISO/IEC 17025 as follows:
 - 7.1.1 Uplift and lateral resistance testing in accordance with *ASTM D1761*
 - 7.1.2 Fastener bending yield testing in accordance with *ASTM F1575*
 - 7.1.3 Fastener shear strength testing in accordance with *ASTM F1575*
 - 7.1.4 Fastener tensile strength testing in accordance with *ASTM F606*
- 7.2 Information contained herein is the result of testing and/or data analysis by sources which conform to the evaluation requirements of *NBC Volume 1 Relationship of the NBC to Standards Development and Conformity Assessment* and/or professional engineering regulations. DrJ relies upon accurate data to perform its ISO/IEC 17065 evaluations.
- 7.3 Where appropriate, DrJ's analysis is based on provisions that have been codified into law through provincial, territorial, or local adoption of codes and standards. The providers of the codes and standards are legally responsible for their content. DrJ analysis may use code-adopted provisions as a control sample. A control sample versus a test sample establishes a product as being equivalent to that prescribed in this code in quality, strength, effectiveness, fire resistance, durability and safety. Where the accuracy of the provisions provided herein is reliant upon the published properties of materials, DrJ relies upon the grade mark, grade stamp, mill certificate, and/or test data provided by material suppliers to be minimum properties. DrJ analysis relies upon these properties to be accurate.

8 FINDINGS

- 8.1 When used and installed in accordance with this TER and the provisions of the applicable building codes defined in Section 2, FrameFAST™ fasteners have the factored design value properties defined herein and are approved for use as an alternative to those fasteners prescribed by the applicable code.
- 8.2 This product has been evaluated in the context of the codes listed in Section 2 and is compliant with all known provincial, territorial, and local building codes. Where there are known variations in provincial, territorial, or local codes applicable to this TER, they are listed here.
- 8.2.1 No known variations
- 8.3 NBC Volume 1 Relationship of the NBC to Standards Development and Conformity Assessment:

Certification

Certification is the confirmation by an independent organization that a product or service meets a requirement...Certification bodies publish lists of certified products and companies.

Evaluation

An evaluation is a written opinion by an independent professional organization that a product will perform its intended function in a building. An evaluation is very often done to determine the ability of an innovative product, for which no standards exist, to satisfy the intent of the Code requirement...Several organizations, including the Canadian Construction Materials Centre (CCMC), offer such evaluation services.

- 8.4 Valid *evaluations* are obtained from *independent professional organizations*, which include but are not limited to ISO/IEC 17065 accredited evaluation services and professional engineers.⁴
- 8.5 ISO/IEC 17065 accreditation bodies, including but not limited to SCC and ANAB, confirm that product certification bodies have the expertise to provide *evaluation* services within their scope of accreditation. All SCC and ANAB product certification bodies meet NBC requirements to offer *evaluation* services for *alternative solutions*.⁵
- 8.5.1 DrJ is an ISO/IEC 17065 ANAB-Accredited Product Certification Body – Accreditation #1131 and employs professional engineers.⁶
- 8.6 Product certification organizations, accredited by the SCC and ANAB, are defined as equivalent *evaluation* services:
- 8.6.1 The Canada-United States-Mexico Agreement (CUSMA) Article 11.6 Conformity Assessment confirms mutual recognition by stating, “...each Party shall accord to conformity assessment bodies located in the territory of another Party treatment no less favorable than that it accords to conformity assessment bodies located in its own territory or in the territory of the other Party.”
- 8.6.2 The SCC National Conformity Assessment Principles states, “SCC is a member of a number of international organizations developing voluntary conformity assessment agreements that help ensure the international acceptance of Canadian conformity assessment results. Signatories to these agreements (like SCC) recognize each other’s accreditations as being equivalent to their own.”⁷
- 8.7 Building official approval of a licensed professional engineer is performed by verifying that the professional engineer and/or their business entity are listed by the licensing board of the relevant jurisdiction.

⁴ NBC Division C Article 2.2.1.2

⁵ NBC Division A Clause A-1.2.1.1.(1)(b) provides information on code compliance via alternative solutions and defines alternative solutions as “...achiev[ing] at least the minimum level of performance required by Division B.” NBC Division C Section 2.3 includes additional guidance for documentation of alternative solutions.

⁶ Through ANAB accreditation and the IAF MLA, DrJ certification can be used to obtain material, product, design, or method of construction approval in any jurisdiction or country that has IAF MLA Members & Signatories to meet the Purpose of the MLA – “certified once, accepted everywhere.”

⁷ The National Conformity Assessment Principles states, “Product regulations and standards may vary from country to country. If these are set arbitrarily, they could be deemed as protectionist. The World Trade Organization (WTO) Agreement on Technical Barriers to Trade (TBT Agreement) is intended to ensure that technical regulations, standards and conformity assessment procedures of member countries do not create unnecessary obstacles to trade. Under the TBT Agreement, members of the WTO agree to use international standards, including conformity assessment standards and guides, as a basis for their technical requirements.”



9 CONDITIONS OF USE

- 9.1 The FrameFAST™ fasteners covered in this TER shall be installed in accordance with Section 6 of this TER and the manufacturer's installation instructions.
 - 9.1.1 For conditions not covered in this TER, connections shall be designed in accordance with accepted engineering practice.
- 9.2 Manufacturer's installation instructions shall be shipped to the jobsite with the materials or otherwise be available on the jobsite for inspection.
- 9.3 Loads applied shall not exceed those recommended by the manufacturer or as defined in this TER.
- 9.4 Where required by the *authority having jurisdiction* (AHJ) where the project is to be constructed, this TER and the installation instructions shall be submitted at the time of permit application.
- 9.5 Any generally accepted engineering calculations needed to show compliance with this TER shall be submitted to the AHJ for review and approval.
- 9.6 Design loads shall be determined in accordance with the building code adopted by the jurisdiction in which the project is to be constructed and/or by the *designer* (e.g., *owner*).
- 9.7 At a minimum, this product shall be installed per Section 6 of this TER.
- 9.8 This product has an internal quality control program and a third-party quality assurance program in accordance with ISO/IEC 17065 certification procedures.
- 9.9 The actual design, suitability, and use of this TER, for any particular building, is the responsibility of the owner or the owner's authorized agent.
- 9.10 This TER shall be reviewed for code compliance by the AHJ in concert with the duties and powers granted to the building official by the provincial regulations governing such duties and powers.
- 9.11 The implementation of this TER for this product is dependent on the design, quality control, third-party quality assurance, proper implementation of installation instructions, inspections, and any other code or regulatory requirements that may apply.

10 IDENTIFICATION

- 10.1 The product(s) listed in Section 1.1 are identified by the designation "FrameFAST™" on the packaging material bearing the manufacturer's name, product name, TER number, and other information to confirm code compliance.
- 10.2 The packaging shall include OMG's name and address, fastener size, third-party inspection agency, and TER number.
- 10.3 Additional technical information can be found at fastenmaster.com.

11 REVIEW SCHEDULE

- 11.1 This TER is subject to periodic review and revision. For the most recent version, visit drjcertification.org.
- 11.2 For information on the current status of this TER, contact DrJ Certification.